

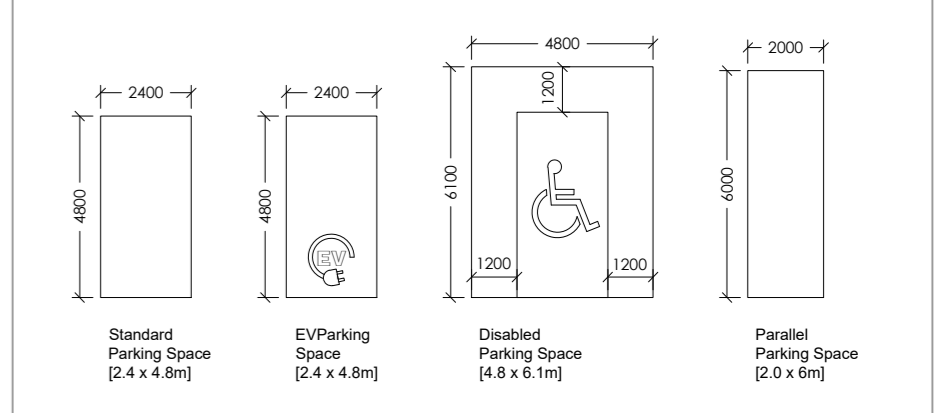

NOTE: - DO NOT SCALE. USE FIGURED DIMENSIONS ONLY.
- THIS DRAWING IS TO BE READ IN CONJUNCTION WITH ALL RELEVANT SPECIFICATIONS AND DRAWINGS.
- ALL DIMENSIONS TO BE CHECKED ON SITE.
- IN THE EVENT OF ANY DISCREPANCIES BETWEEN DRAWINGS THE CONTRACTOR IS TO INFORM THE ARCHITECT IMMEDIATELY.

REV.	DATE	DESCRIPTION	DRWN.	CHKD.	APP'D.
A	10/20/10	Issue for Planning	000	PH	PH

PARKING SPACE TYPES



PARKING PLAN

- In Curtilage Resident's Parking
- On Street Resident's Parking
- Under Podium Resident's Parking
- Designated Creche / Commercial Parking
- Visitor Parking
- EV Parking Spaces
- Disabled Parking Spaces

CAR PARKING

Required Spaces	Total No. of Units	Residential (1 per 1 & 2 Bed Units)		Residential (2 per 3 & 3+ Bed Units)		Creche (1 per 6 children)		Retail (1 per 50 sqm)		Total
		1150	545.0	1028.0	37.8	8.0	1700			
Provided Spaces		Regular	Disabled	EV	Visitor	Total				
	In Curtilage	942	0	0	0	942				
	On Street	106	11	23	10	150				
	Under Podium	84	6	27	3	120				
TOTAL	1132	17	50	13	1212					

BICYCLE PARKING

	No. of Units	No. of Beds	Required Spaces	Provided Spaces
Block A	137	214	282.5	296
Block B	113	174	230.5	296
Block C	91	158	203.5	239
Block D	45	74	98.0	50
Block E	64	111	143.0	144
Block F	12	24	30.0	30
Block G	16	32	40.0	40
Block H	16	32	40.0	40
Block K	8	16	20.0	20
Magin House	2	5	6.0	6
Gale Lodge	1	1	1.5	2
Creche			9.1	9
Commercial Units			4.0	4
TOTAL	508	841	1108.1	1186

Site Plan - Parking Plan
Scale 1:1250 @A0

